

Date	Prepared by	Approved by	Document nos	Revision
13 Feb 2019	Ray Ling	Patrick Yeo	MS-4.2-IM-001	0

## **INSTRUCTION MANUAL MS-4.2DB60**

### **TABLE OF CONTENTS:**

#### **1.00 BEAMS & CONNECTORS:**

- 1.10 Plan View Resultant Beam And Connector Layout
- 1.20 HB and LB Connector
- 1.30 Connector Ports Table

#### **2.00 PATTERN DIAGRAM**

- 2.10 High Band
- 2.20 Low Band

#### **3.00 MANUAL TILT ADJUSTMENT**

#### **4.00 TRANSPORTATION / INSTALLATION**

- 4.10 Transportation (From Point to Point)
- 4.20 Bracket Mounting
- 4.30 Installation using a crane
- 4.31 Lifting the Antenna

#### **Revision History:**

Date	Description	Revised by	Revision nos.

# 1.00 BEAMS & CONNECTORS:

## 1.10 Plan View Resultant Beam And Connector Layout

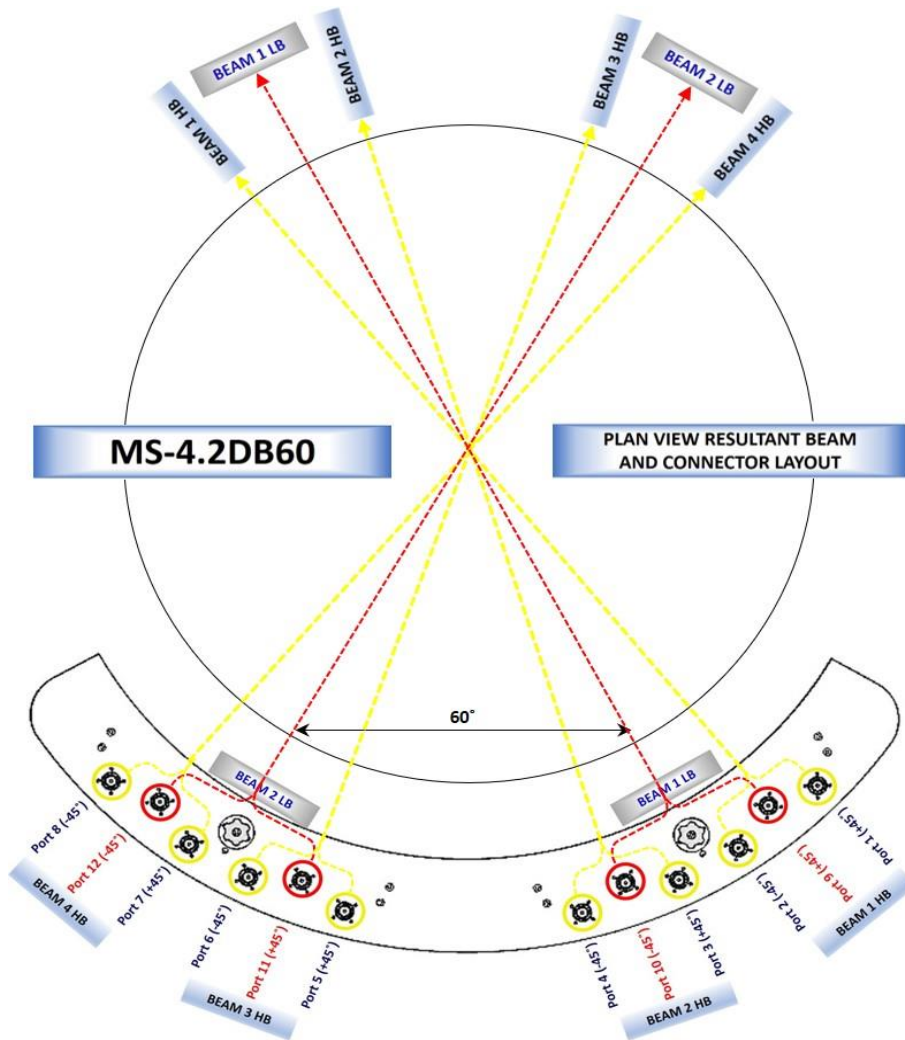

## 1.20 HB and LB Connector

PLAN VIEW CONNECTOR LAYOUT

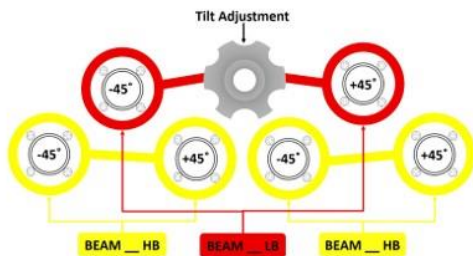

UPWARD REAR VIEW CONNECTOR LAYOUT

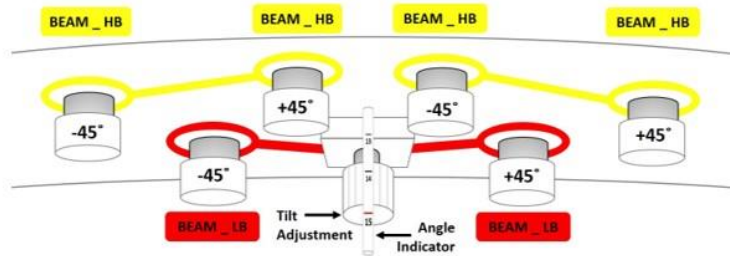

## 1.30 Connector Ports Table

BEAM 2 LB				BEAM 1 LB			
Port 12 (-45°)		Port 11 (+45°)		Port 10 (-45°)		Port 9 (+45°)	
BEAM 4 HB		BEAM 3 HB		BEAM 2 HB		BEAM 1 HB	
Port 8 (-45°)	Port 7 (+45°)	Port 6 (-45°)	Port 5 (+45°)	Port 4 (-45°)	Port 3 (+45°)	Port 2 (-45°)	Port 1 (+45°)

## 2.00 PATTERN DIAGRAM

### 2.10 High Band

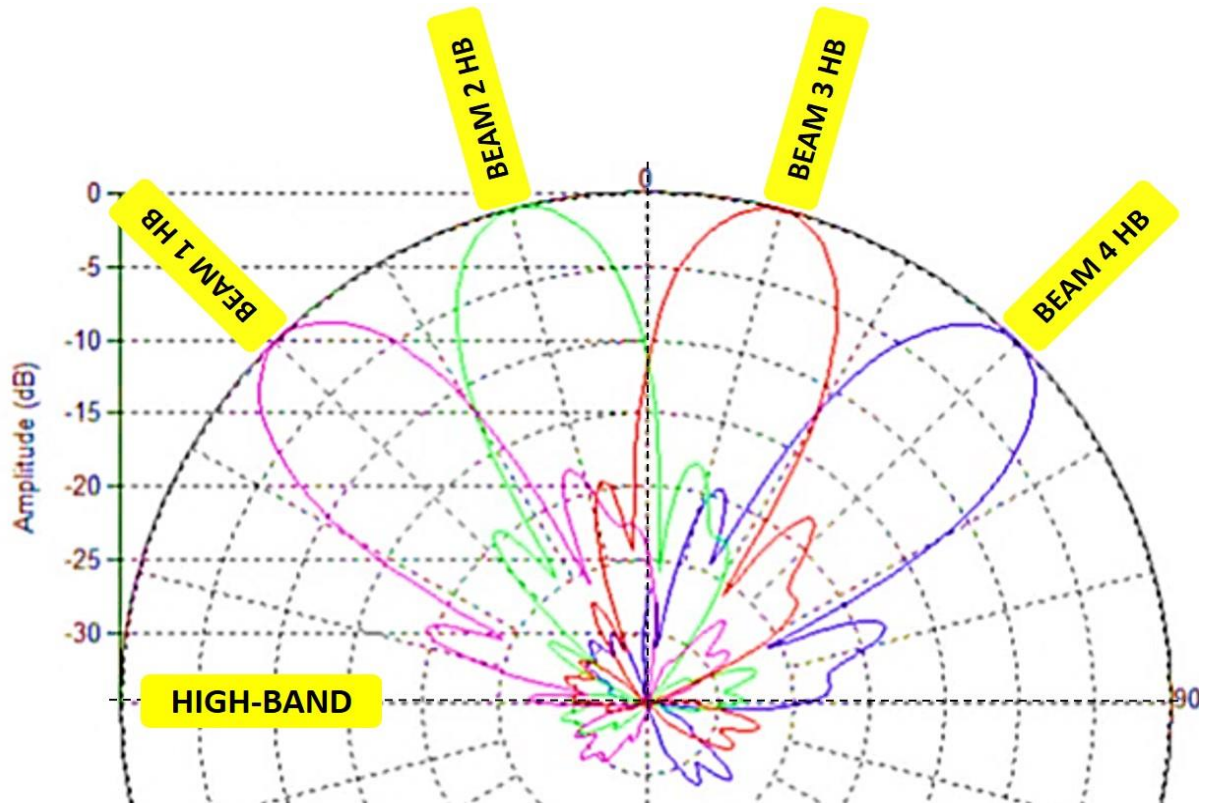

### 2.20 Low Band

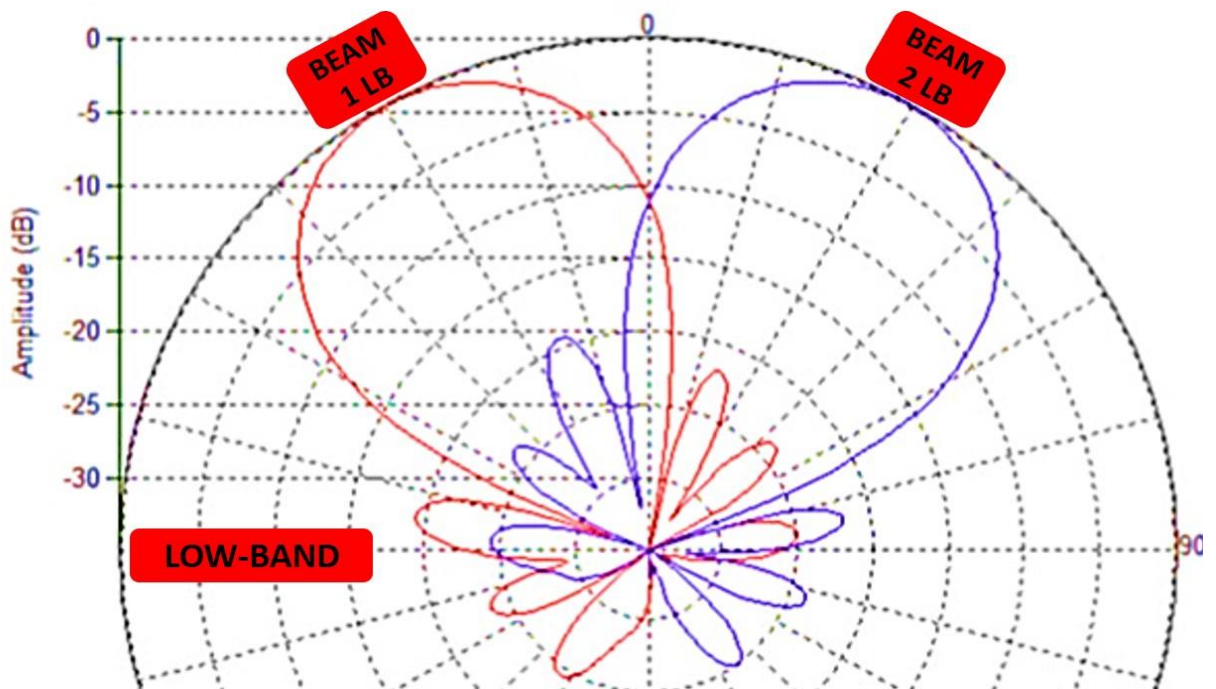

### 3.00 MANUAL TILT ADJUSTMENT

Tilt can be adjusted up to 15° on the antenna for each 60° sector (combination of 2 high band beams, 1 low band beam). For example Beam 1,2 HB and Beam 1 LB can be tilted together (as one sector), Beam 3,4 HB and Beam 2 LB can be tilted together as one sector and so on.

There are 2 ways of adjustment: 1. By Hand turning. 2. Use Screw Driver as shown in pictured below. When using this method, please be extra careful not to adjust tilt beyond the 0-15° tilt range, as there is no restrictor on the tilt knob.

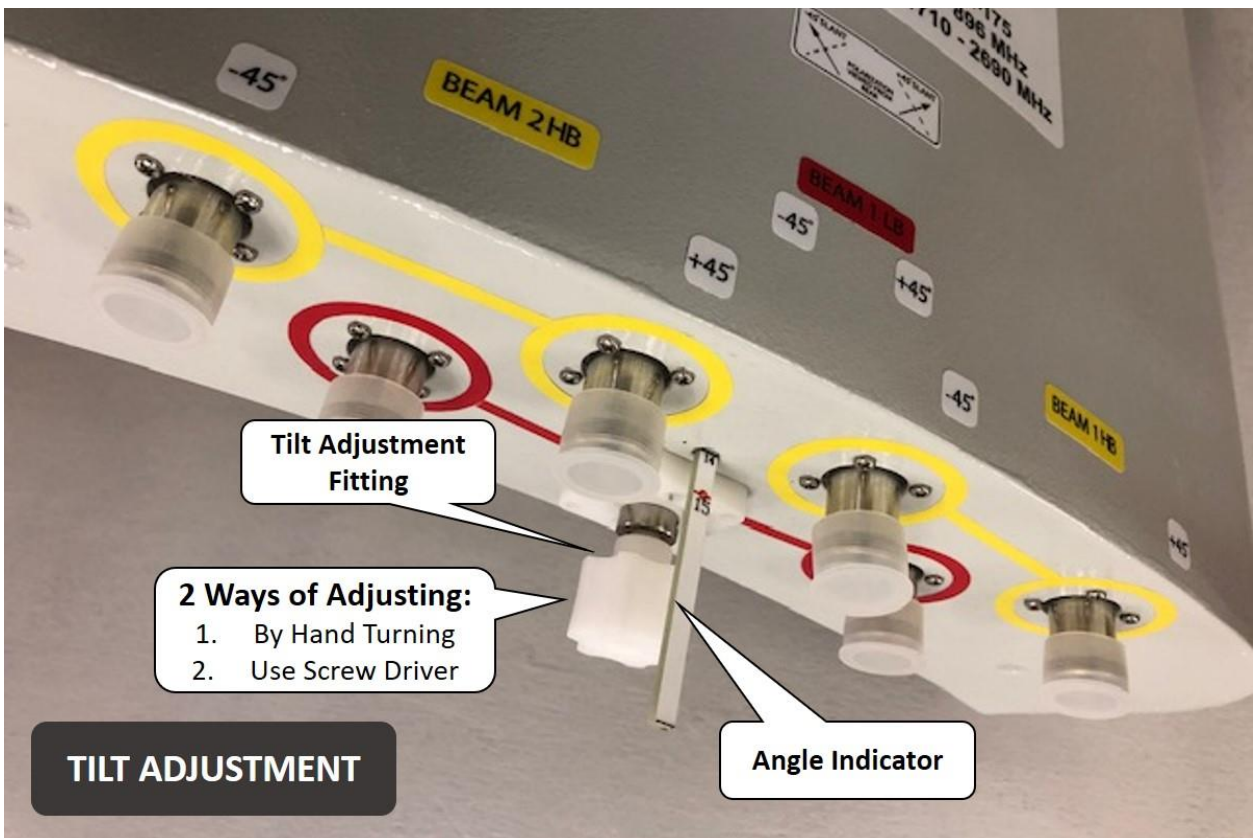

## 4.00 TRANSPORTATION / INSTALLATION

### 4.10 Transportation (From Point to Point)

Strictly comply to the Local authority and regulatory on Workplace Safety and Health Control and Measure when moving and transportation of large or heavy equipment, appropriate material handling machine should be use. **(Risk Assessment apply for Forklift or Pallet Truck Lifting)**

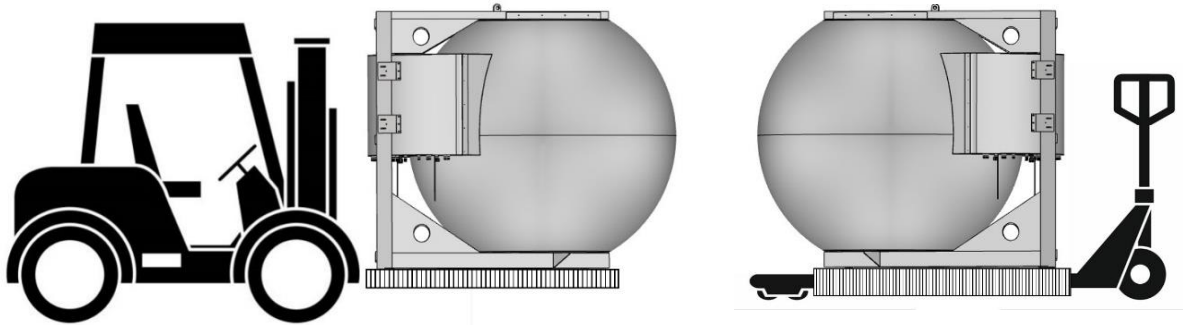

### 4.20 Bracket Mounting

Model	Bracket Qty (pc)	Bolt & Nuts Size	Bolts Set (pc)
MS-12.6DB180	6	M14 x 15cm	12
MS-8.4DB120	4	M12 x 15cm	8
MS-6.3DB90	4	M12 x 15cm	8
MS-4.2DB60	4	M12 x 15cm	8

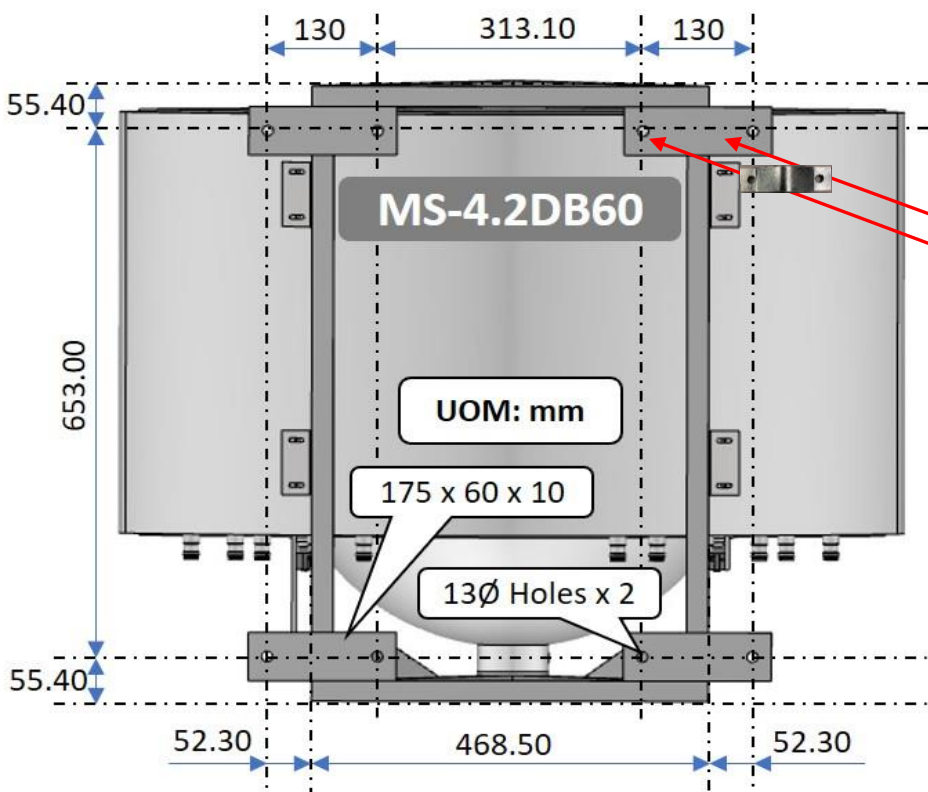

Tighten to the pole with Bolt & Nuts Sets

**Important Notes:**  
End User is require to Custom-Make the additional supporting bracket and tighten to the existing Antenna bracket to meet the deployment needs.

### 4.30 Installation using a crane

Strictly comply to the Local authority and regulatory on Workplace Safety and Health Control and Measure when performing lifting of large or heavy equipment, appropriate material handling machine should be use and only certified personal should perform the task. **(Risk Assessment require to apply for both Up-Lifting and Down-Lifting.)**

### 4.31 Lifting the Antenna

The antenna has 2 hook points installed on the top frame (located slightly behind the center of the sphere). These hooks are designed at the center of gravity point of the antenna. A cable, rope can be securely fastened to the hooks and the antenna can be lifted using a crane or forklift as pictured below.

