

MS-LP-6-F2

Lens Technology Enabled™ Multi-Beam Antenna perfect for up to 6 sectors CRAN, Outdoor DAS and Small Cell deployment. This antenna is capable of 2X2 MIMO with a coverage footprint of 360°. Each beam has two full-band ports. 3.3GHz – 4.2GHz. Factory-installed tilt settings are available for 0° & 30°.

Model

0° Light Pole Antenna Model # MS-LP-6-F2

30° Light Pole Antenna Model # MS-LP-6-F2-30°

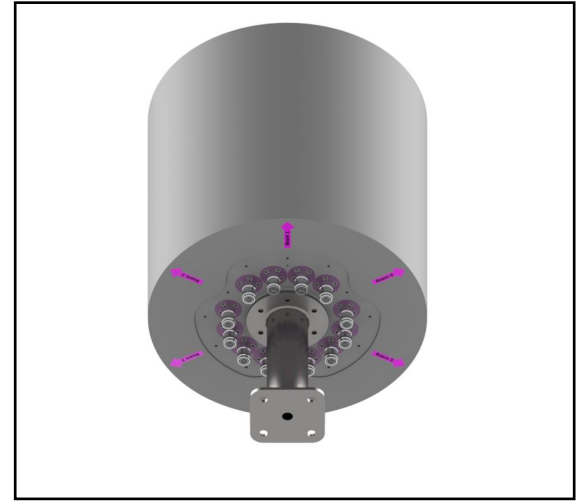

PATTERN RESULTS:

Horizontal Pattern (3.5GHz)

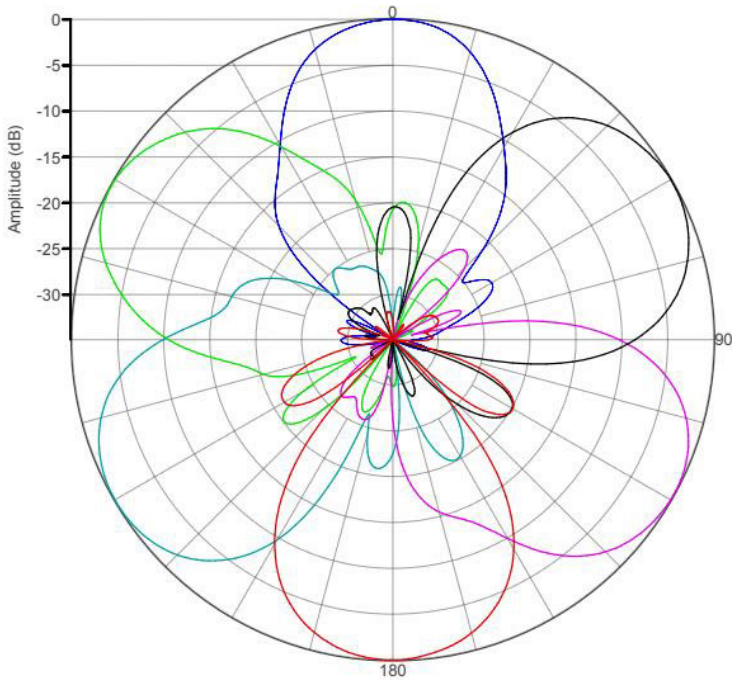

Vertical pattern at 0° tilt and 30° tilt (3.5GHz)

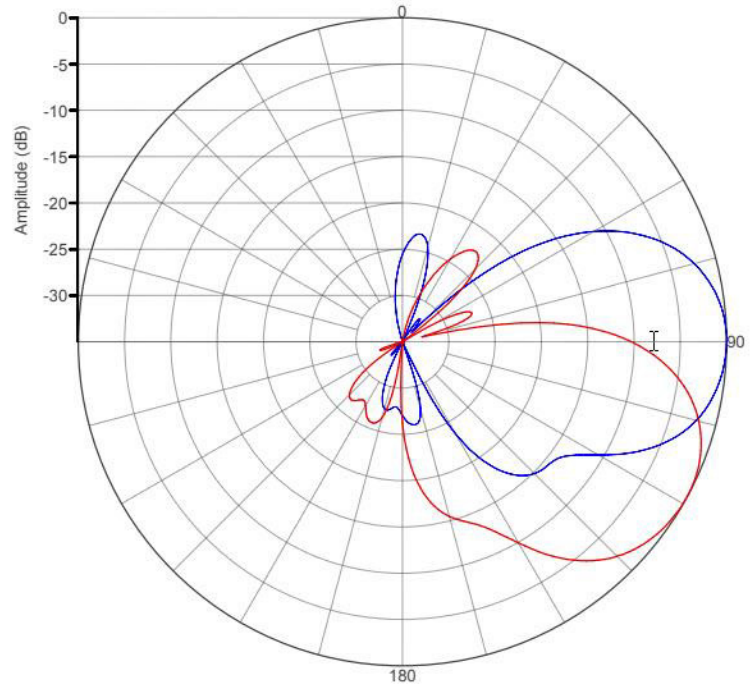

TECHNICAL SPECIFICATIONS

Frequency	3300 MHz – 4200 MHz
Gain	14dBi
VSWR	<1.5:1
Polarization	Dual Slant ±45°
Horizontal Coverage	360°
Horizontal Beamwidth (10dB level)	60°
Horizontal Beamwidth (3dB level)	34°
Vertical Beamwidth (3dB level)	34°
Beam Cross-over	10dB typical
Total Number of Beams	6
Number of Ports per Beam	2
Number of Ports Total	12
Tilt Per Cross-Pol	0°, 30°
First Sidelobe level	<-15dB
Front to Back Ratio	>28dB
Isolation Port to Port - Polarization	>28dB
Isolation Port to Port - Beam	>28dB
Power Rating	100W per port
Intermodulation	<-153dBc
Impedance	50 ohm
Connector Quantity and Type	12 x 4.3-10 female

MECHANICAL DATA

Dimensions (H x W x D)	Cylindrical Design Diameter: 36.5 cm / 14.4 inches Total Height: 47 cm / 18.5 inches
Antenna Weight	6kg 13.2lbs
Radome Material	Fiber Glass
Mounting	1 position pipe holder, bottom or side mountable. Compatible pipe diameter: 6.1 – 11.4 cm 2.4 – 4.5 inch

ENVIRONMENTAL RATINGS

Humidity	95% RH @ +30°C
Temperature	-40°C to +70°C
Wind load @ 150km/h	N/lbf Frontal: 100.3/22.5 Lateral: 100.3/22.5

CONNECTOR LAYOUT:

