

Date	Prepared by	Approved by	Document nos	Rev
21 Feb 2024	Ray Ling	Pavel	MS-MBA-3-H4-IM-001	3

INSTRUCTION MANUAL MS-MBA-3-H4

TABLE OF CONTENTS:

1.00 BEAMS & CONNECTORS:

- 1.10 Plan View Resultant Beam Layout
- 1.20 Connector Ports Table
- 1.30 Connector Detail
- 1.40 Connector Layout

2.00 PATTERN DIAGRAM

- 2.10 Frequency: 1710 - 2690 MHz
- 2.11 Horizontal Pattern
- 2.12 Vertical Pattern

3.00 RET Operations / Information

- 3.10 Display & Information Reference (Example of Antenna Unit s/n 33)
- 3.20 Model & S/N Reference From Label
- 3.30 Beam Nos & Port Nos Display

4.00 MANUAL TILT ADJUSTMENT

5.00 BRACKET INSTALLATION

- 5.10 Bolts & Nuts Requirements
 - 5.11 Bolts & Nuts
 - 5.12 Bracket
- 5.20 Tools Requirement
 - 5.21 Adjustable Spanner
 - 5.22 M12 Spanner
- 5.30 Bracket Spacing & Installation Sample

Revision History:

Date	Description	Revised by	Revision nos.
07-Apr-21	To include the bracket installation process.	Ray Ling	1
21-Jan-22	Add RET Handle Caution sticker	Ray Ling	2
21-Feb-24	To Include RET Operations/Information & Add in RET Serial nos. Sticker on the Antenna Backshell	Ray Ling	3

1.00 BEAMS & CONNECTORS:

1.10 Plan View Resultant Beam Layout

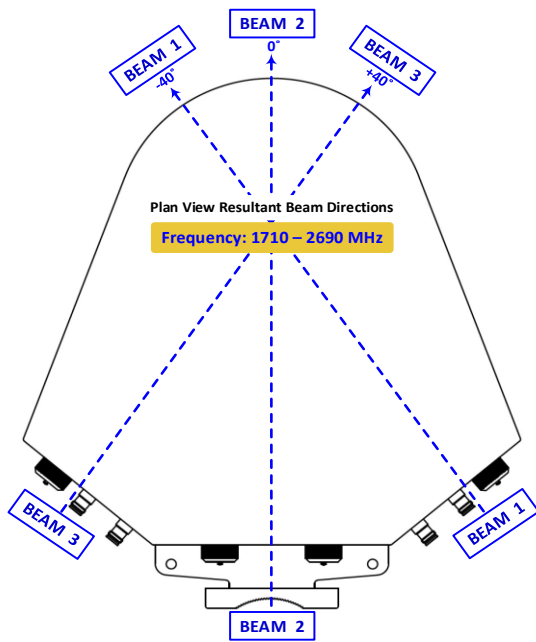

1.20 Connector Ports Table

MS-MBA-3-H4 Connector Table					
BEAM 3		BEAM 2		BEAM 1	
Port 11 (+45°)	Port 12 (-45°)	Port 7 (+45°)	Port 8 (-45°)	Port 3 (+45°)	Port 4 (-45°)
Port 9 (+45°)	Port 10 (-45°)	Port 5 (+45°)	Port 6 (-45°)	Port 1 (+45°)	Port 2 (-45°)

1.40 Connector Layout



REAR VIEW CONNECTOR LAYOUT

1.30 Connector Detail

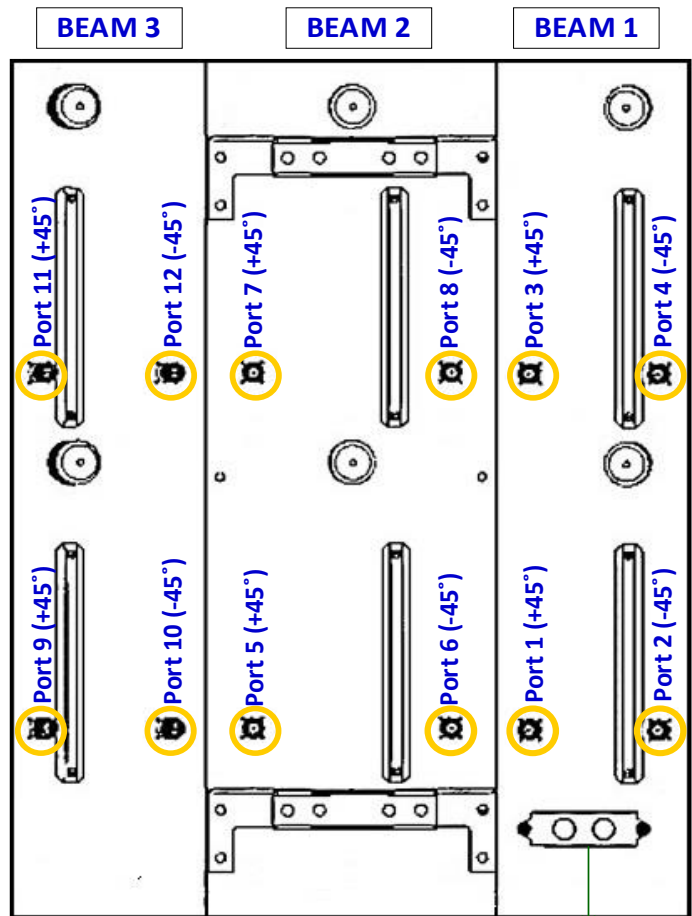
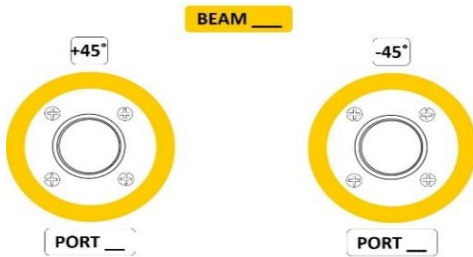

AISG IN
HB Beams: 1,2,3
HB Ports: 1 to 12

2.00 PATTERN DIAGRAM

2.10 Frequency: 1710 - 2690 MHz

2.11 Horizontal Pattern

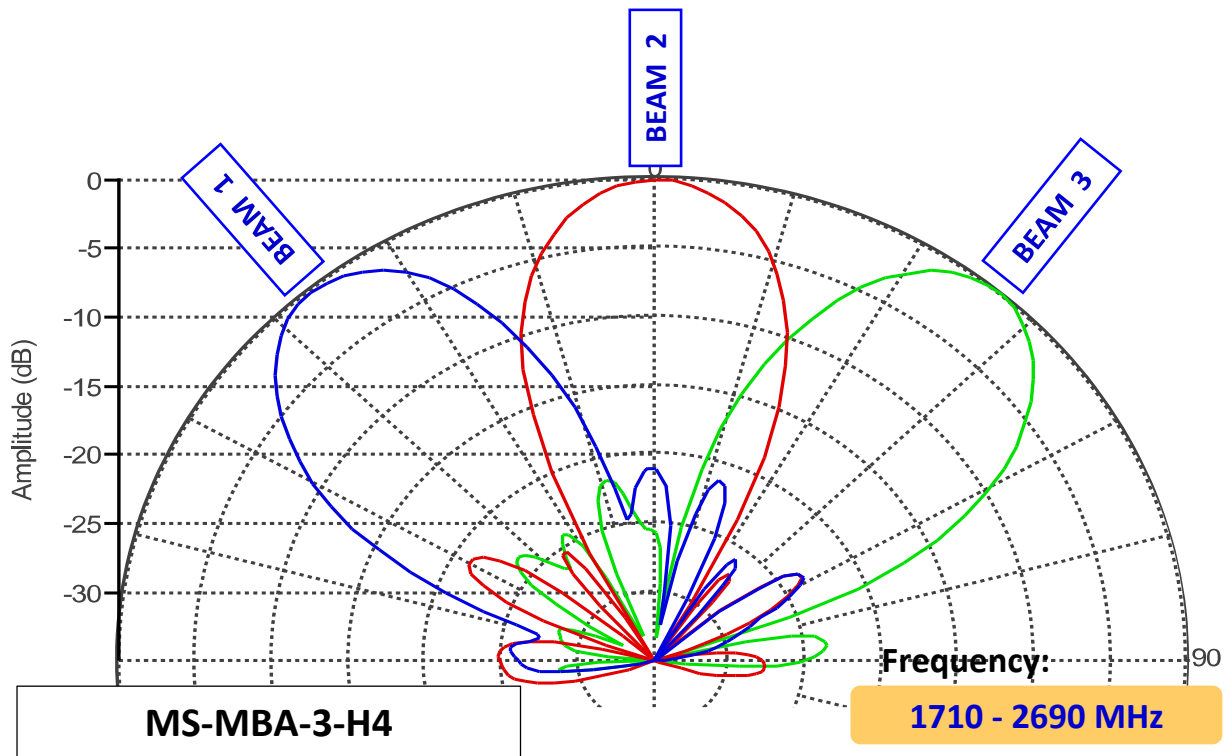

2.12 Vertical Pattern

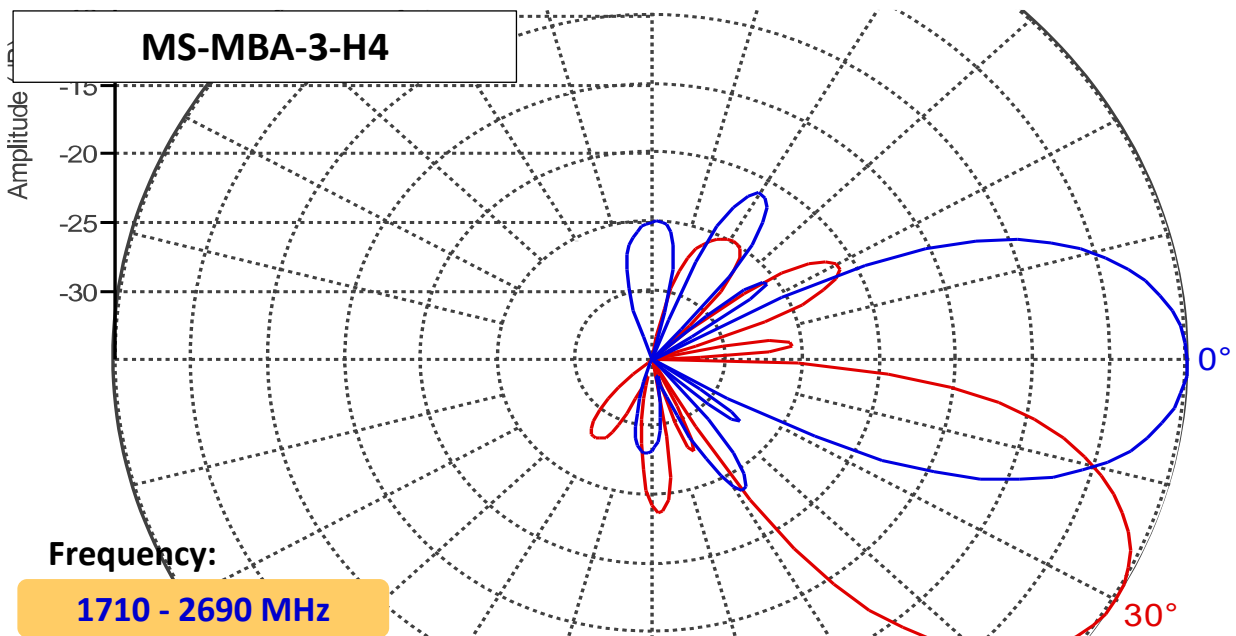

3.00 RET Operations / Information

A standard AISG 2.0 compliant cable (not included) is used to connect the MDCU to the AISG interface control. Once connected, use an AISG 2.0 compliant Control software to perform a Sub Unit SCAN to identify the RET Elements.

3.10 Display & Information Reference (Example of Antenna Unit s/n 33)

ALD List

NO	HDLC	Vendor	Serial Number	Product Number	H/W Version	S/W Version	3GPP	Device	AISG	Connect	Link
1	1	MS	MBA3H4000000033MM	ACS-RMC00	1.00	1.17	6	Multi RET	2	Connect	Link

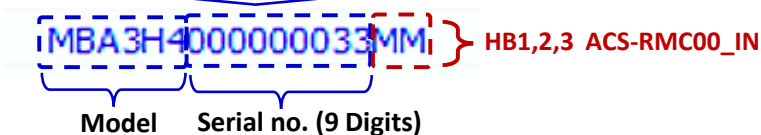

3.20 Model & S/N Reference From Label

Model No. : MS-MBA-3-H4
Serial No. : MS-MBA-3-H4-000033
Frequency: 1710 – 2690 MHz

RET Controller Serial #
MBA3H4000000033MM

Antenna s/nos Sticker

RET Controller s/nos Sticker

Reminder: If Information Has Been Edited, Remember to Perform "Radio Hard Reset" for Changes to take Place

Add Zero in front if the serial nos is shorter than 9 digits

3.30 Beam Nos & Port Nos Display

RET ID : MSMB3H4000000033MM **HB1,2,3 ACS-RMC00_IN (Port Assigned)**

RET Status and Control

Antenna Information List

NO	Sector ID	Ant Model	Ant Serial	Current Tilt	Status
1/6	HB Beam 1 (Ports 1, 2)	MS-MBA-3-H4	MS-MBA-3-H4-00033	0.0	Normal
2/6	HB Beam 2 (Ports 5, 6)	MS-MBA-3-H4	MS-MBA-3-H4-00033	0.0	Normal
3/6	HB Beam 3 (Ports 9, 10)	MS-MBA-3-H4	MS-MBA-3-H4-00033	0.0	Normal
4/6	HB Beam 1 (Port 3, 4)	MS-MBA-3-H4	MS-MBA-3-H4-00033	0.0	Normal
5/6	HB Beam 2 (Ports 7, 8)	MS-MBA-3-H4	MS-MBA-3-H4-00033	0.0	Normal
6/6	HB Beam 3 (Ports 11, 12)	MS-MBA-3-H4	MS-MBA-3-H4-00033	0.0	Normal

4.00 MANUAL TILT ADJUSTMENT

1	The MBA antenna come in RET mode as default, but if needed can also be manually adjusted. To do so, please unscrew the waterproof cap behind the element whose tilt is to be adjusted.
2	By Default the knob is on engaged mode, pull out the handle for manual tilt adjustment, turn the handle to change the tilt.
3	When done, push the handle back in, screw the waterproof cap back to the position.

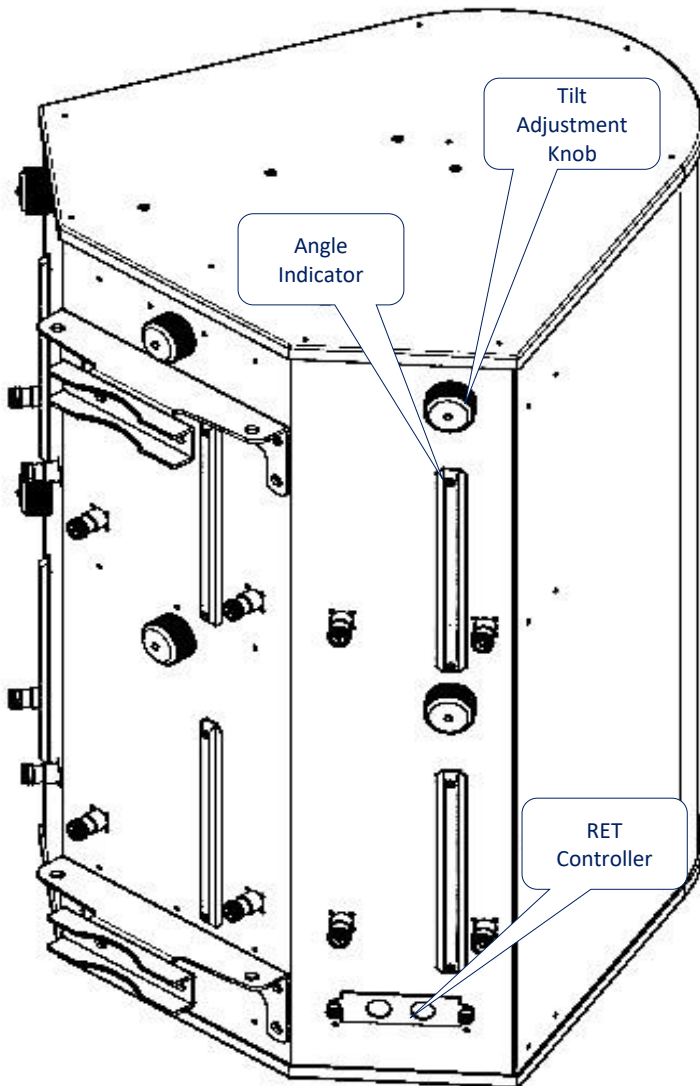

Unscrew/Screw the cap for tilt adjustment process



Engaged with internal RET motor position



Pull handle out to disengaged RET for tilt adjustment

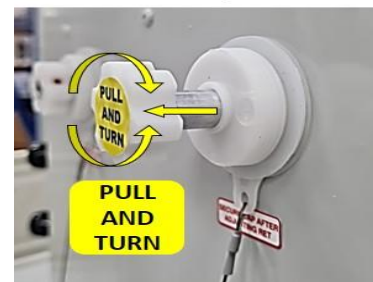

5.00 BRACKET INSTALLATION

5.10 Bolts & Nuts Requirements

Bracket	Bolts		Nuts	
	Qty	Size	Qty	Size
2	M12 x 200mm	4	M12	10
***Additional Lock Nuts M12 x 4pcs				

5.11 Bolts & Nuts

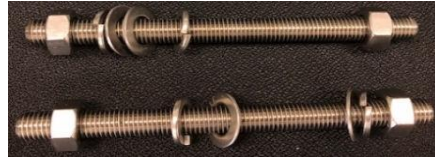

5.12 Bracket



5.20 Tools Requirement

5.21 Adjustable Spanner



5.22 M12 Spanner



5.30 Bracket Spacing & Installation Sample

