

MATSING®

LENS TECHNOLOGY ENABLED

MS-MBA-6.6-F4-H4

Instruction Manual

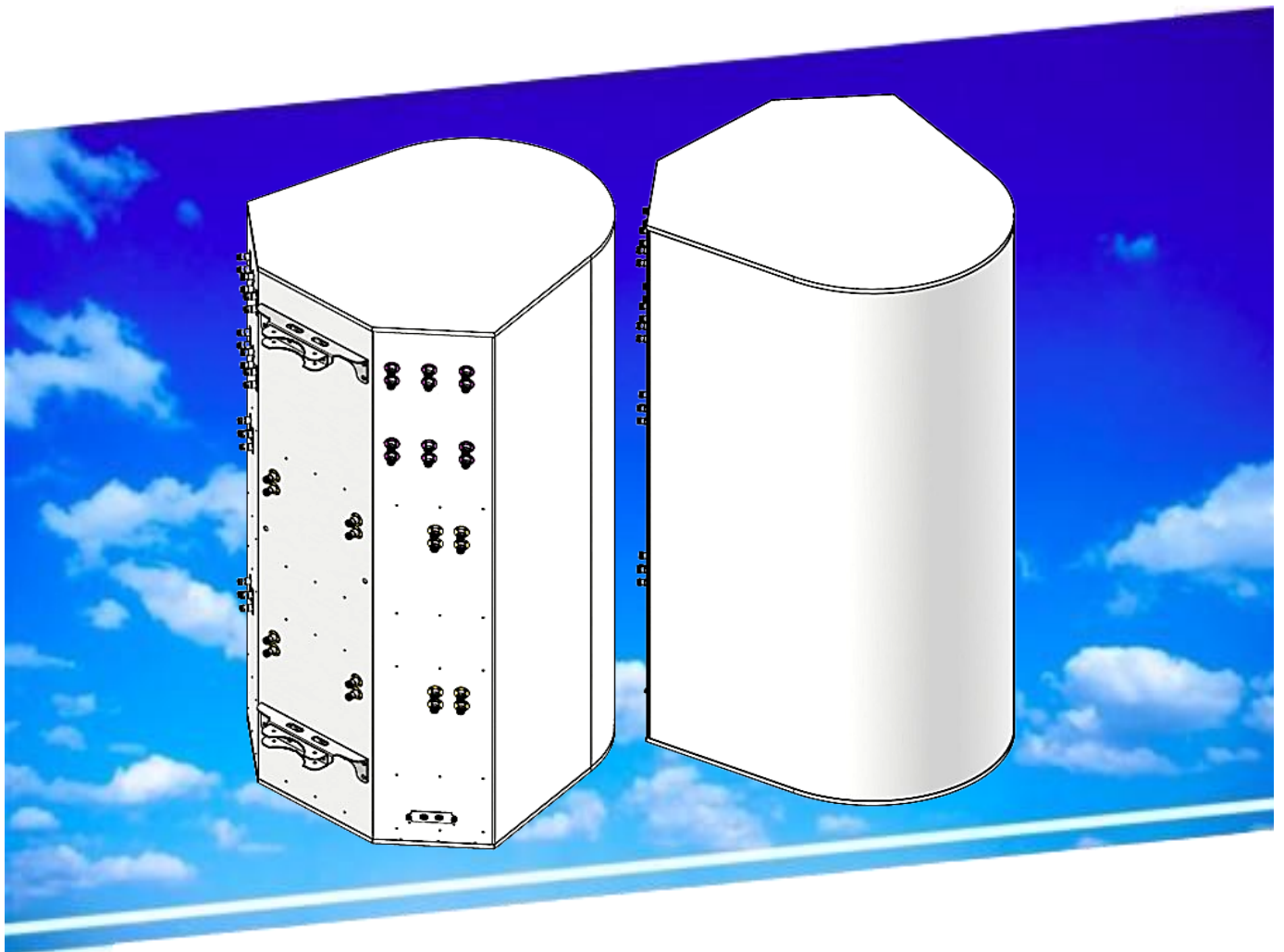

www.matsing.com technicalsupport@matsing.com phone: (800) 867-6429



Table Of Contents

1.00 Pattern diagram

- 1.10 F-Band
 - 1.11 Horizontal pattern
 - 1.12 Vertical pattern
- 1.20 H-Band
 - 1.21 Horizontal pattern
 - 1.22 Vertical pattern

2.00 Beams and connectors

- 2.10 Plan view resultant beam layout
- 2.20 Connector detail
- 2.30 Connector port table
- 2.40 Rear view connector layout

3.00 RET operations and Information

- 3.10 Example of s/no's label reference
- 3.20 Display and information reference
- 3.30 Beam nos and port nos display

4.00 Bracket installation

- 4.10 Bolts and nuts and tools
 - 4.11 Bolts and nuts
 - 4.12 Bracket
- 4.20 Tools requirement
 - 4.21 Adjustable spanner
 - 4.22 M12 Spanner
- 4.30 Bracket spacing and installation sample

Revision History:

<u>Date</u>	<u>Description</u>	<u>Rev By</u>	<u>Check By</u>	<u>Rev no</u>
17-Jan-2025	Initial Release	RL	Pavel	0

1.00 Pattern diagram

1.10 F-Band

1.11 Horizontal pattern

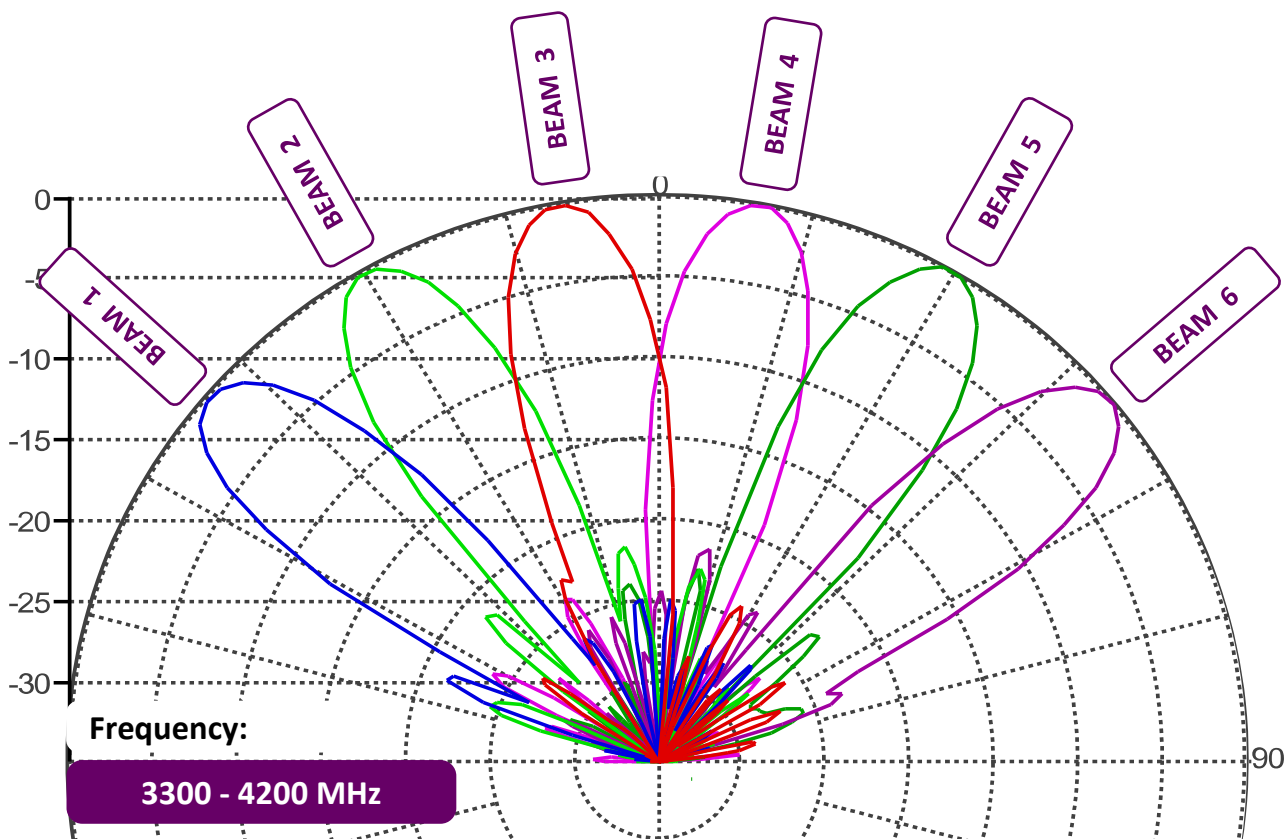

1.12 Vertical pattern

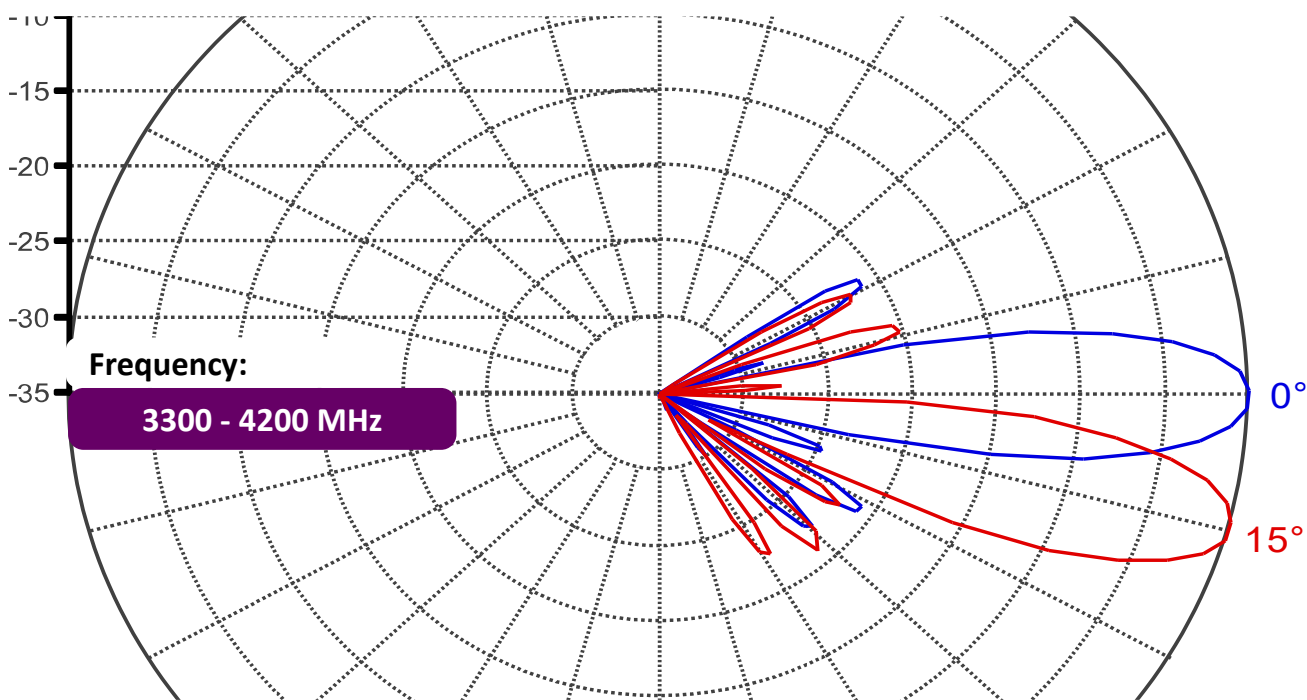

1.20 H-Band

1.21 Horizontal pattern

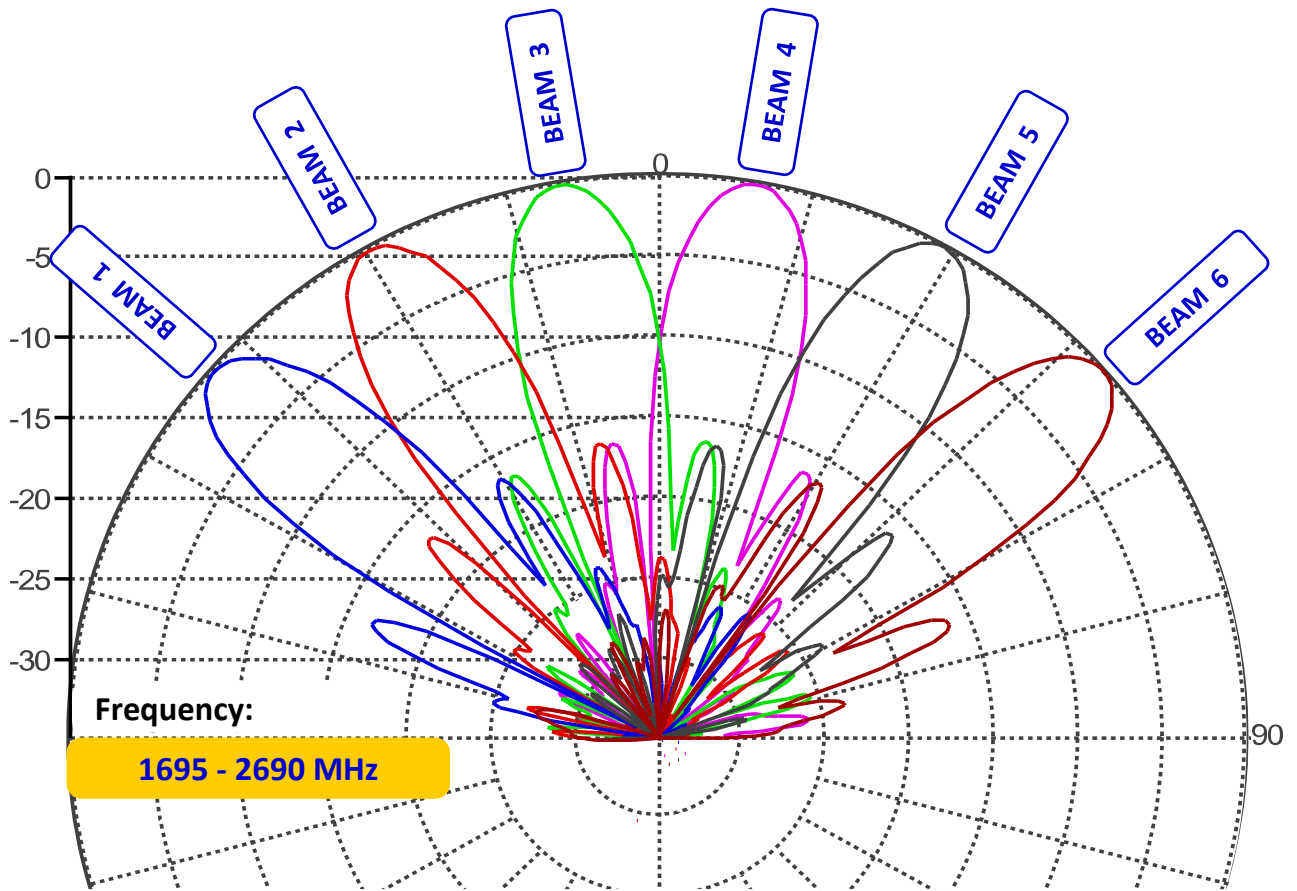

1.22 Vertical pattern

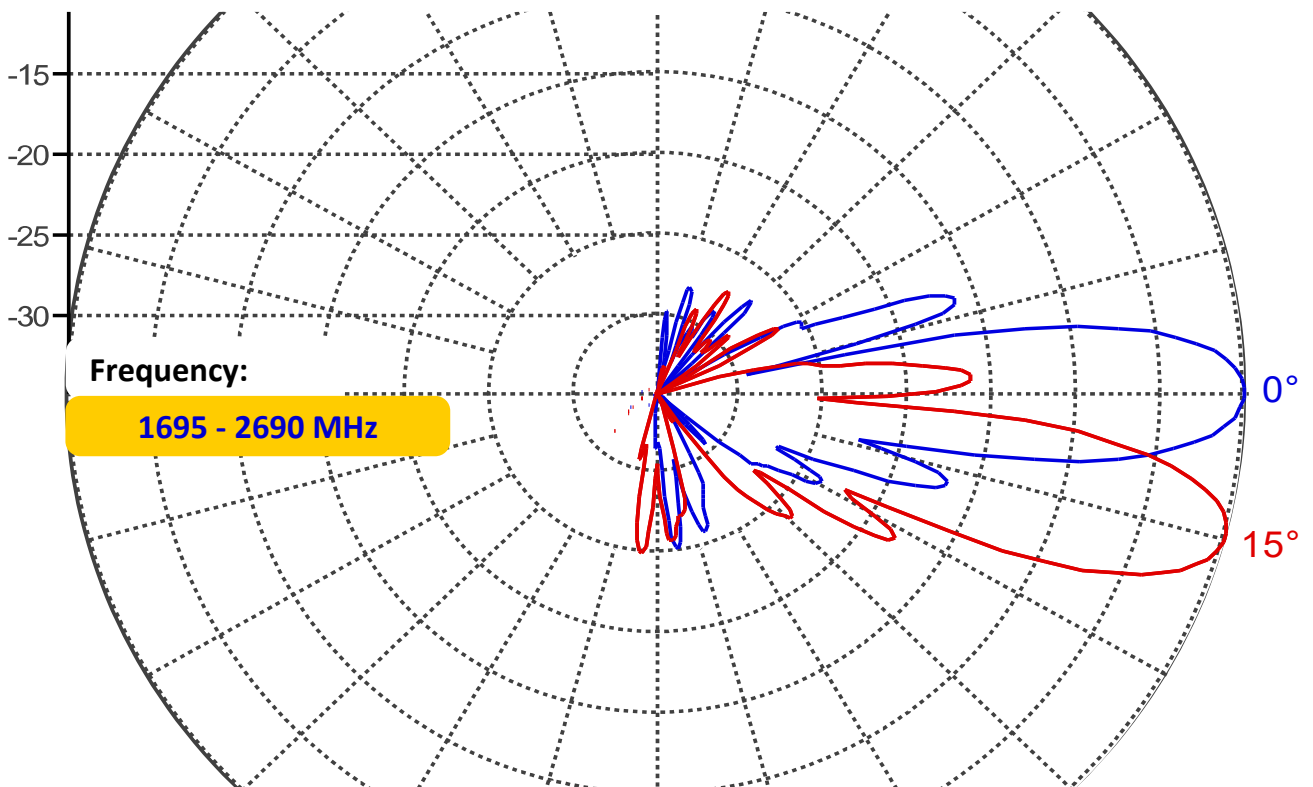

2.00 Beams and connectors

2.10 Plan view resultant beam layout

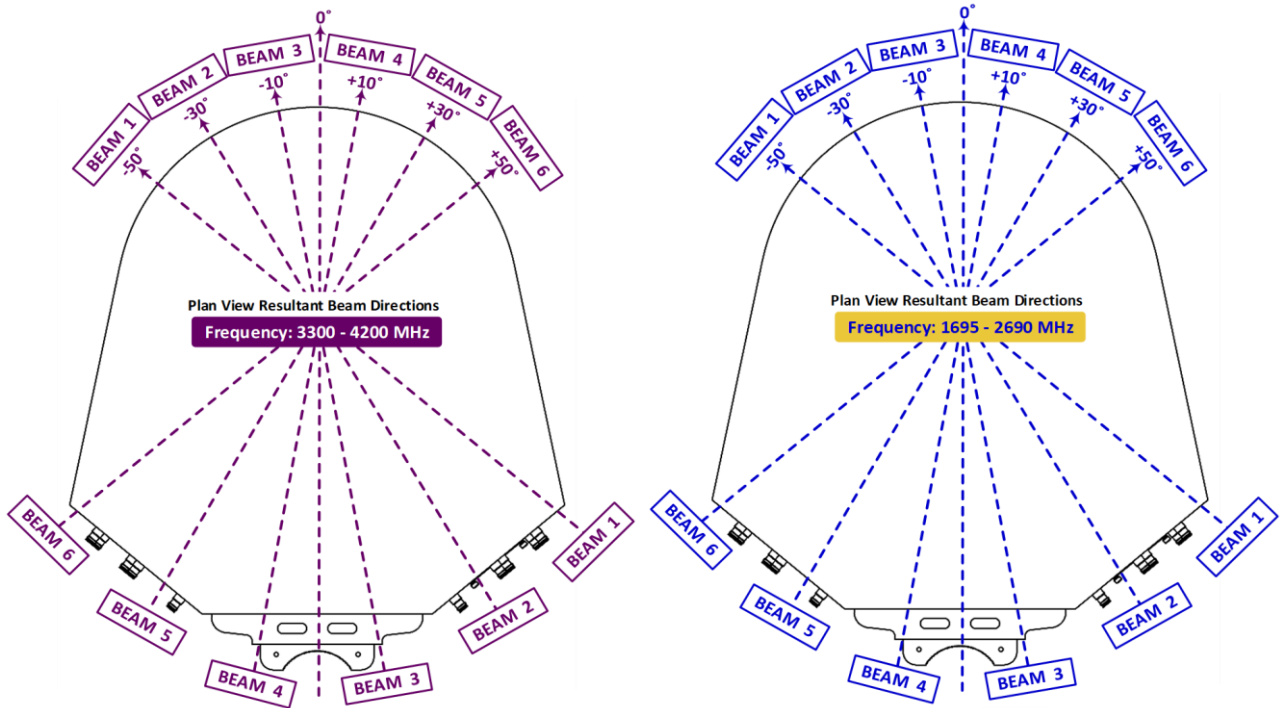

2.20 Connector detail

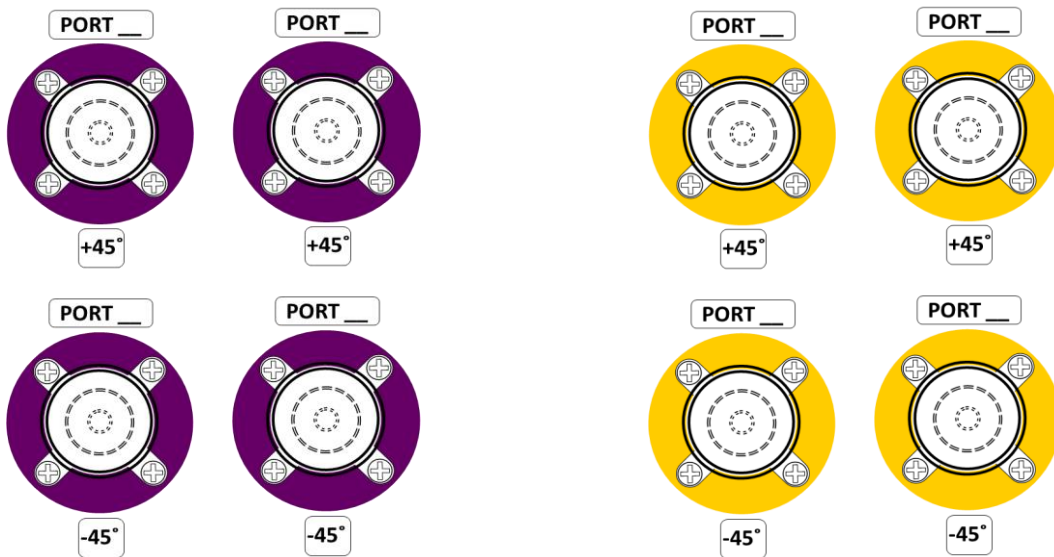

2.30 Connector port table

BEAM 6	BEAM 5	BEAM 4	BEAM 3	BEAM 2	BEAM 1
Port 23 (+45°)	Port 19 (+45°)	Port 15 (+45°)	Port 11 (+45°)	Port 7 (+45°)	Port 3 (+45°)
Port 24 (-45°)	Port 20 (-45°)	Port 16 (-45°)	Port 12 (-45°)	Port 8 (-45°)	Port 4 (-45°)
Port 21 (+45°)	Port 17 (+45°)	Port 13 (+45°)	Port 9 (+45°)	Port 5 (+45°)	Port 1 (+45°)
Port 22 (-45°)	Port 18 (-45°)	Port 14 (-45°)	Port 10 (-45°)	Port 6 (-45°)	Port 2 (-45°)
BEAM 6	BEAM 5	BEAM 4	BEAM 3	BEAM 2	BEAM 1
Port 47 (+45°)	Port 43 (+45°)	Port 39 (+45°)	Port 35 (+45°)	Port 31 (+45°)	Port 27 (+45°)
Port 48 (-45°)	Port 44 (-45°)	Port 40 (-45°)	Port 36 (-45°)	Port 32 (-45°)	Port 28 (-45°)
Port 45 (+45°)	Port 41 (+45°)	Port 37 (+45°)	Port 33 (+45°)	Port 29 (+45°)	Port 25 (+45°)
Port 46 (-45°)	Port 42 (-45°)	Port 38 (-45°)	Port 34 (-45°)	Port 30 (-45°)	Port 26 (-45°)

2.40 Rear view connector layout

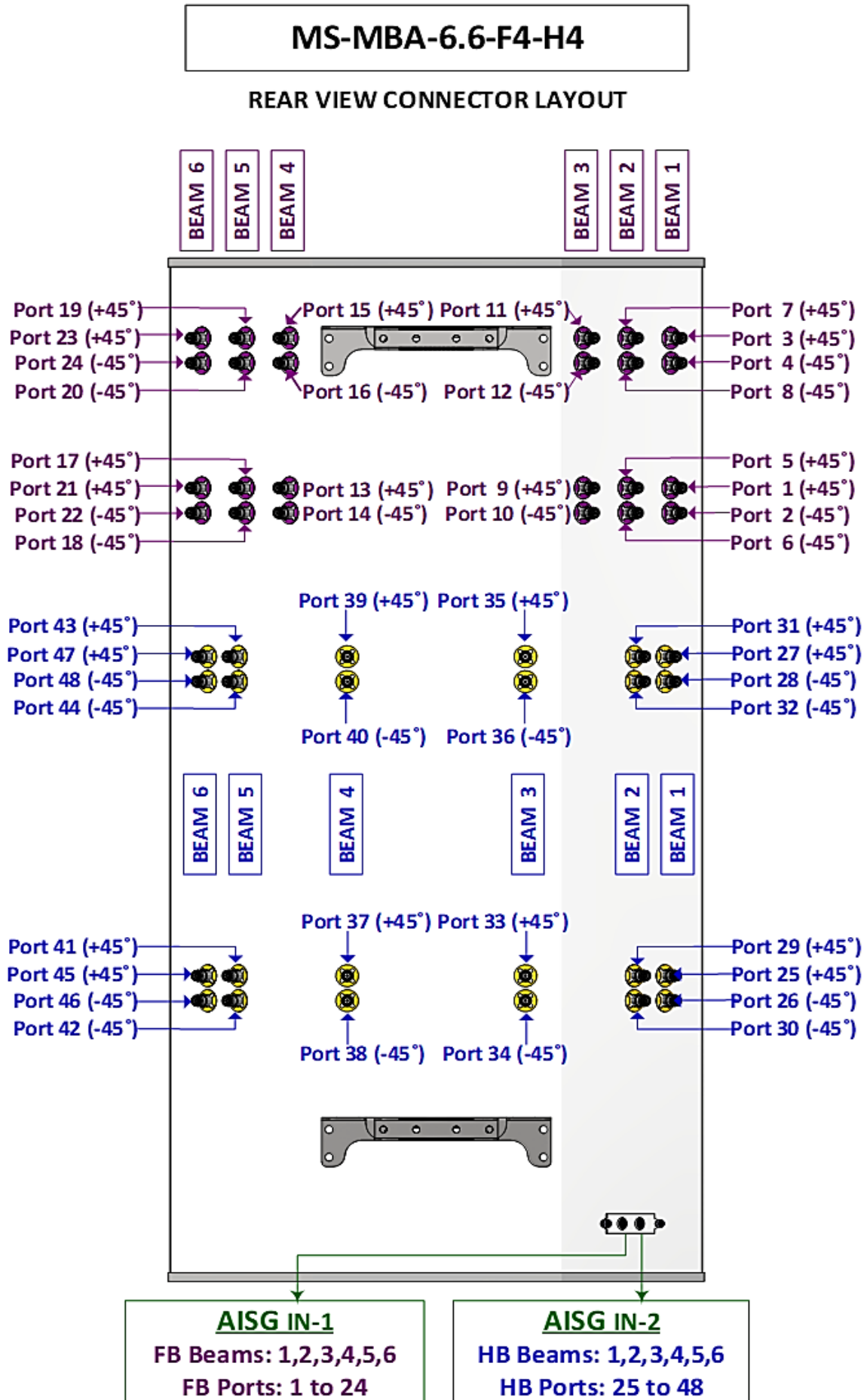

3.00 RET operations and Information

A standard AISG 2.0 compliant cable (not included) is used to connect the MDCU to the AISG interface control. Once connected, use an AISG 2.0 compliant Control software to perform a Sub Unit SCAN to identify the RET Elements.

3.10 Example of s/no's label reference

MATSING
LENS TECHNOLOGY ENABLED

Model No. : MS-MBA-6.6-F4-H4
Serial No. : MS-MBA-6.6-F4-H4-00001
Frequency: 1695 – 2690 MHz
3300 – 4200 MHz

RET Controller Serial #
MBA66F4H40001AMM
MBA66F4H40001BMM

Delete Zero in front if the serial nos is more than 4 digits

Reminder: If Information Has Been Edited, Remember to Perform "Radio Hard Reset" for Changes to take Place

3.20 Display and information reference

ALD List

NO	HDL	Vendor	Serial Number	Product Number	H/W Version	S/W Version	3GPP	Device	AISG	Connect	Link
1	1	MS	MBA66F4H40001AMM	ACS-RMC20	1.00	1.17	6	Multi RET	2	Connect	Link
2	2	MS	MBA66F4H40001BMM	ACS-RMC20	1.00	1.17	6	Multi RET	2	Connect	Link

MBA66F4H40001AMM ACS-RMC20 (Dual Channel Controller AISG IN-1)
MBA66F4H40001BMM ACS-RMC20 (Dual Channel Controller AISG IN-2)

Model s/no. 4 digits

3.30 Beam nos and port nos display

RET ID : MSMBA66F4H40001AMM

RET Status and Control

Antenna Information List

NO	Sector ID	Art Model	FB 6	FB 5	FB 4	FB 3	FB 2	FB 1
1/6	FB 1 (Ports 1, 2, 3, 4)	MS-MBA6.6-F4-H4	P23+	P19+	P15+	P11+	P 7+	P 3+
2/6	FB 2 (Ports 5, 6, 7, 8)	MS-MBA6.6-F4-H4	P24-	P20-	P16-	P12-	P 8-	P 4-
3/6	FB 3 (Ports 9, 10, 11, 12)	MS-MBA6.6-F4-H4	P21+	P17+	P13+	P 9+	P 5+	P 1+
4/6	FB 4 (Ports 13, 14, 15, 16)	MS-MBA6.6-F4-H4	P22-	P18-	P14-	P10-	P 6-	P 2-
5/6	FB 5 (Ports 17, 18, 19, 20)	MS-MBA6.6-F4-H4						
6/6	FB 6 (Ports 21, 22, 23, 24)	MS-MBA6.6-F4-H4						

RET ID : MSMBA66F4H40001BMM

RET Status and Control

Antenna Information List

NO	Sector ID	Art Model	HB 6	HB 5	HB 4	HB 3	HB 2	HB 1
1/6	HB 1 (Ports 25, 26, 27, 28)	MS-MBA6.6-F4-H4	P47+	P43+	P39+	P35+	P31+	P27+
2/6	HB 2 (Ports 29, 30, 31, 32)	MS-MBA6.6-F4-H4	P48-	P44-	P40-	P36-	P32-	P28-
3/6	HB 3 (Ports 33, 34, 35, 36)	MS-MBA6.6-F4-H4	P45+	P41+	P37+	P33+	P29+	P25+
4/6	HB 4 (Ports 37, 38, 39, 40)	MS-MBA6.6-F4-H4	P46-	P42-	P38-	P34-	P30-	P26-
5/6	HB 5 (Ports 41, 42, 43, 44)	MS-MBA6.6-F4-H4						
6/6	HB 6 (Ports 45, 46, 47, 48)	MS-MBA6.6-F4-H4						

4.00 Bracket installation

4.10 Bolts and nuts and tools

4.11 Bolts and nuts



Mounting Bracket	Mounting Bolts		Nuts	
	Qty	Size	Qty	Size
	2	M12x200mm	4	M12

4.12 Bracket



4.20 Tools requirement

4.21 Adjustable spanner

4.22 M12 Spanner

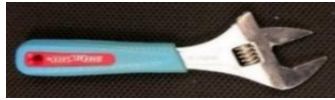

4.30 Bracket spacing and installation sample

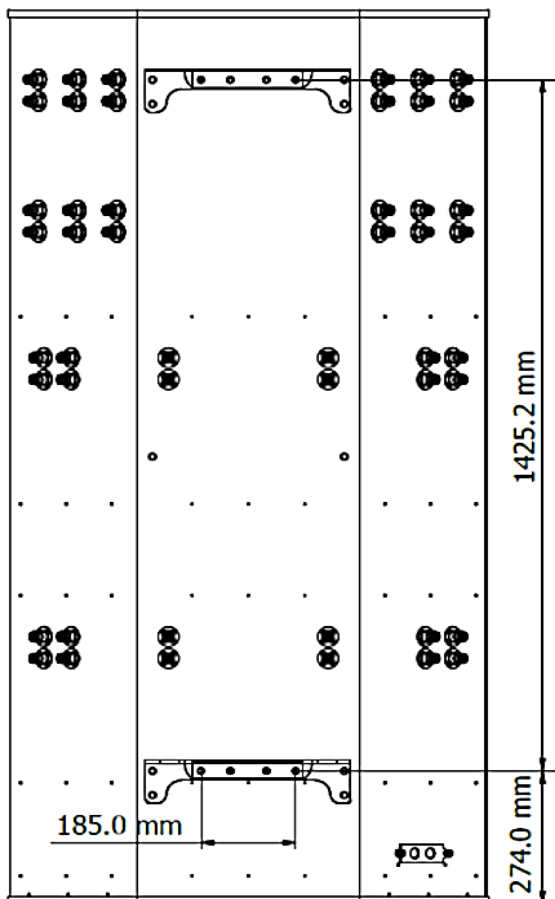
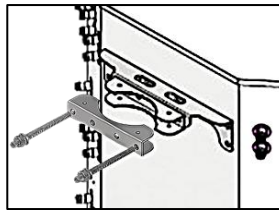

Before installation

Before installation

