

## MS-MBA-6.6-F4-H4

**Lens Technology Enabled™ Multi-Beam Dual Band Base-Station Antenna utilizes a patented spherical lens design with 6 isolated F-Band (3300MHz – 4200MHz) cross-polarized beams, 6 isolated High Band (1695 MHz – 2690 MHz) cross-polarized beams, each F & H Band beams have 4 ports to support 4X4 MIMO. RET for F Band & High Band Beams 0°-15°.**

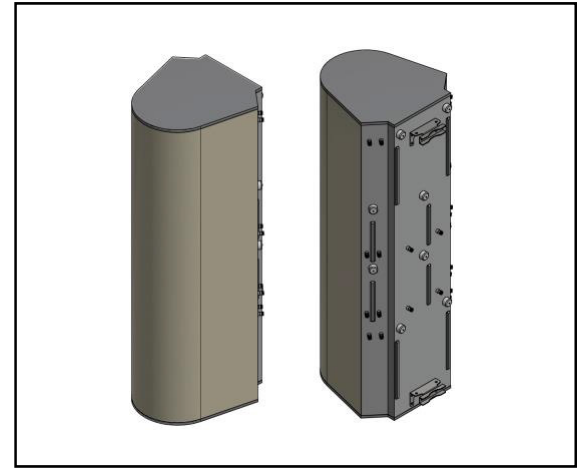

### PATTERN RESULTS:

**F-Band Horizontal Pattern (3.5GHz)**

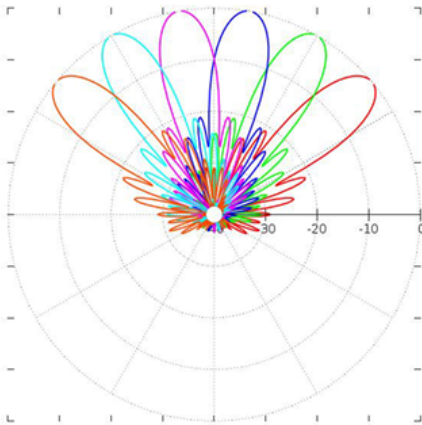

**F-Band Vertical pattern (3.5GHz) at tilt 0° and 15°**

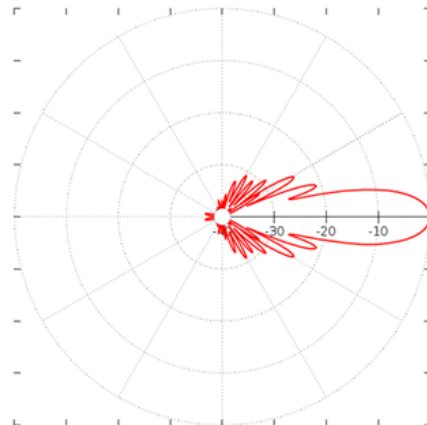

**High-Band Horizontal Pattern (1.92GHz)**

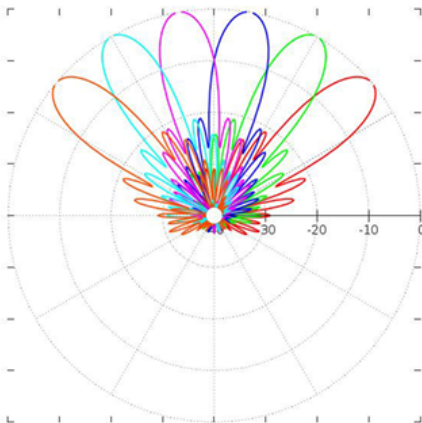

**High-band Vertical Pattern (1.92GHz) at tilt 0° and 15°**

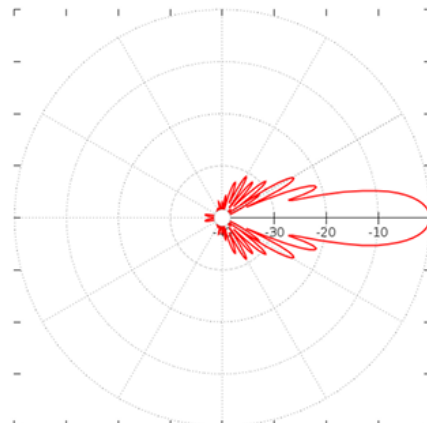

PRELIMINARY

### TECHNICAL SPECIFICATIONS PER BEAM

Frequency	3300-4200 MHz	1695-2690 MHz
Gain	21.5dBi	21dBi
VSWR	<1.5:1	<1.5:1
Polarization	Dual Slant ±45°	Dual Slant ±45°
Horizontal Coverage	120°	120°
Horizontal Beamwidth (10dB)	23°	23°
Horizontal Beamwidth (3dB)	13°	13°
Vertical Beamwidth (10dB)	23°	23°
Vertical Beamwidth (3dB)	13°	13°
Beam Cross-over	10dB typical	10dB typical
Total Number of Beams	6	6
Number of Ports per Beam	4	4
Number of Ports Total	24	24
Tilt Per Cross-Pol; Remote Electrical Tilt (AISG 2.0)	0° - 15°	0° - 15°
First Sidelobe Level	<-16dB	<-15dB
Front to Back Ratio	>28dB	>28dB
Isolation Port to Port - Polarization	>28dB	>28dB
Isolation Port to Port - Beam	>28dB	>28dB
Power Rating	200W per port	200W per port
Intermodulation	<-153dBc	<-153dBc
Impedance	50 ohm	50 ohm
Connector Quantity and Type	24 x 4.3-10 female	24 x 4.3-10 female

### MECHANICAL DATA

Dimensions (H x W x D)	190 x 93.4 x 108.4 cm 74.8 x 36.8 x 42.7 inch
Antenna Weight	75 kg 165 lbs
Radome Material	Fiber Glass
Mounting	Standard pipe mount Compatible pipe diameter: 6.1 – 11.4 cm 2.4 – 4.5 inch

### ENVIRONMENTAL RATINGS

Humidity	95% RH @ +30°C
Temperature	-40°C to +70°C
Wind load @150km/hr	N/ibf Frontal: 1050/263 Lateral: 1406/316

### CONNECTOR LAYOUT

